

1. (12 points) A pentomino is made by five connected squares that touch only on a complete side.

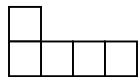

Is a pentomino

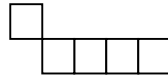

Is not a pentomino

Two pentominos are the same if they can be matched by turning or flipping, as shown.

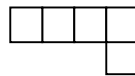
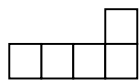

Find the 12 different pentomino shapes.

2. (12 points) Find the measures of $\angle 1$, $\angle 2$, $\angle 3$, and $\angle 4$ if some angles formed are related as shown and $l \parallel m \parallel n$.

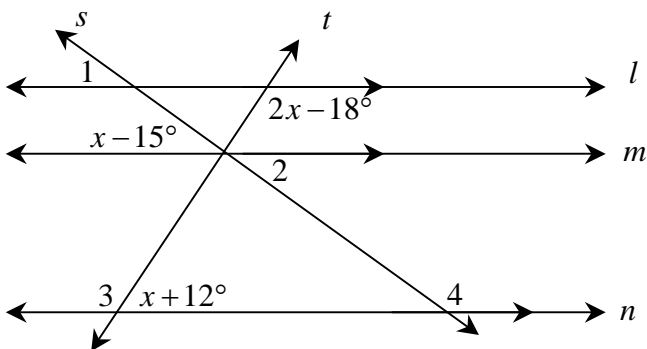

3. (12 points) Find the missing angle measures in each of the following polygons.

a.

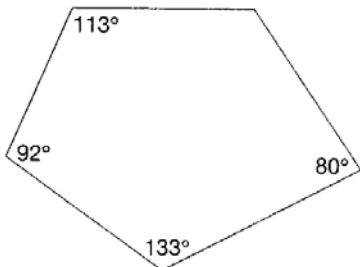

b.

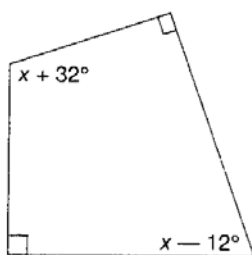

c.

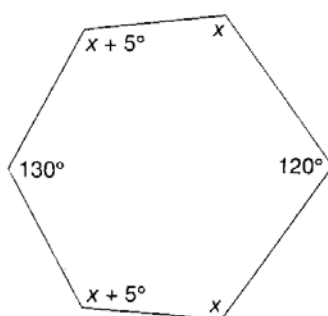

4. (5 points) Which, if either, of the following two triangles has the larger area.

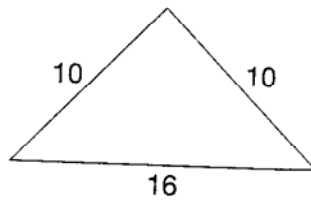
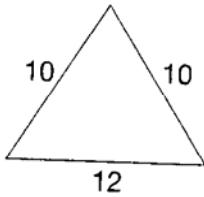

5. (9 points) A trapezoid is illustrated on a square lattice.



- What is its area?
 - If all dimensions of the trapezoid are tripled, what is the area of the resulting trapezoid?
 - If the ratio of lengths of sides of two trapezoids is 1:3, what is the ratio of the areas of the trapezoids?
6. (5 points) Find the length of the side not given.

a.

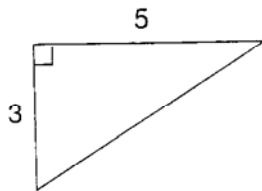

b.

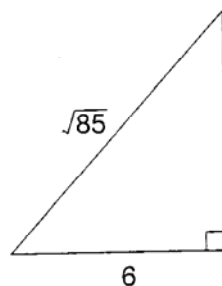

7. (9 points) Find the surface area.

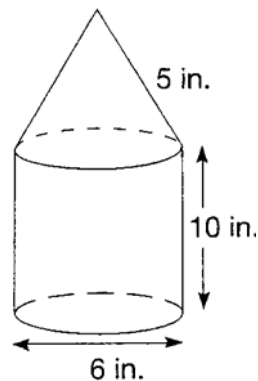

8. (12 points) Find the surface area of each right prism with the given features.
- The bases are equilateral triangles with sides of length 8; height=10.
 - The bases are trapezoids with bases of lengths 7 and 9 perpendicular to one side of length 6; height=12
 - The base is a right triangle with legs of length 5 and 12; height=20
9. (8 points) Refer to the following figure.

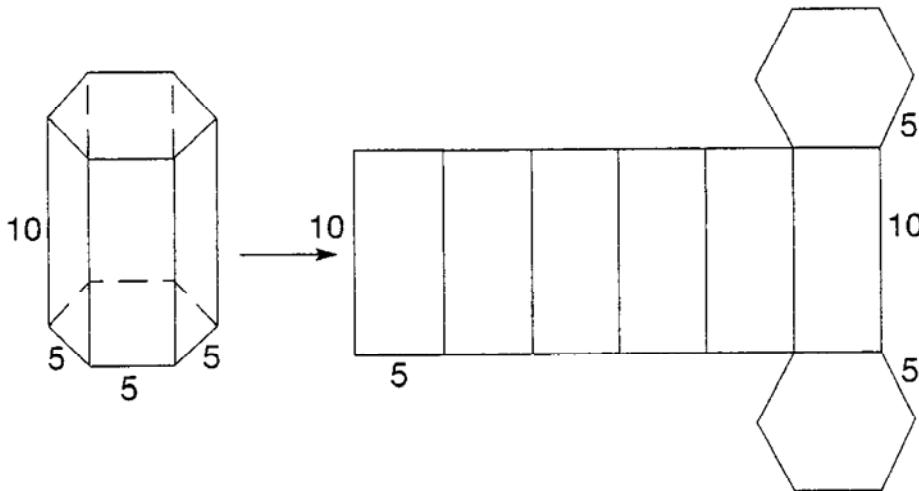

- Find the area of each hexagonal base.
 - Find the total surface area of the prism.
10. (8 points) In the following figure, $AC=20$, $CE=5$, $DE=3$, and $BE=9$. Determine if $\triangle ABE \sim \triangle CDE$. Justify your answer.

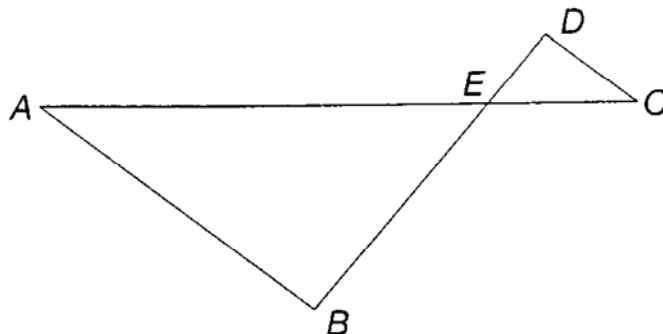

11. (8 points) Determine which of the following pairs of triangles are congruent. Justify your conclusion.

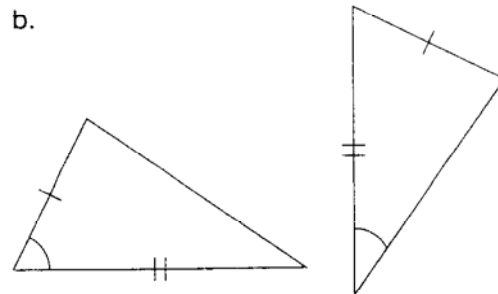
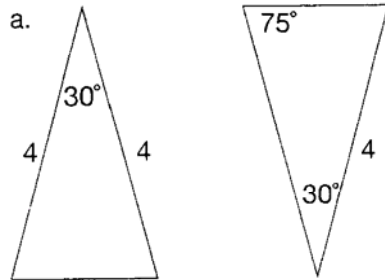

12. (8 points) Verify that the following pair of triangles are congruent. Give the justification of your answer.

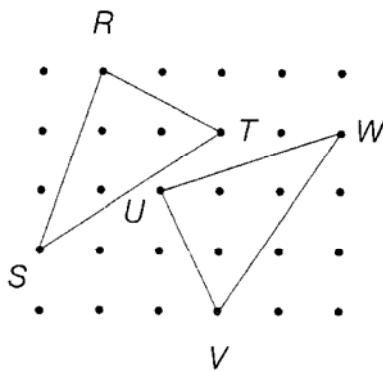

13. (5 points) Find the distance between the following pairs of points. $(0,0)$, $(3,-2)$

14. (5 points) Find the coordinates of the midpoint of the segment that has the following endpoints coordinates $(0, 2)$ and $(-3, 2)$.

15. (5 points) Find the standard deviation of the following data set: 10, 40, 20, 30, 30. Show all work clearly.
16. (20 points) Given the following data set:
45, 35, 5, 70, 65, 40, 33, 72, 65, 50, 35, 42, 8, 7, 12, 23
- a) Make an ordered stem-and-leaf plot.
 - b) Find the 5 number summary.
 - c) Determine the outliers.
17. (12 points) A coin is tossed 3 times.
- a) Write all the different outcomes using a tree diagram
 - b) What is the probability that no head is observed
 - c) What is the probability that at least 2 heads are observed?
 - d) What is the probability that at most 1 tail is observed?
18. (15 points) A jar has 8 red marbles and 6 green marbles. If two marbles are drawn from the jar
- a) show the probability of drawing two different marbles if the marbles are drawn with replacement .
 - b) show the probability of drawing two different marbles if the marbles are drawn without replacement.
19. (10 points) In the figure below the original shape has been shaded and labeled “o”. The figures labeled “A” and “B” have been translated from the original.

Give the code for translation for A and B

From original to figure A

From original to figure B

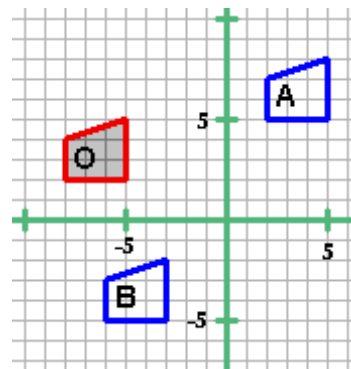

20. (20 points) a) Give the **coordinates** of the vertices of figure ABC.

A _____

B _____

C _____

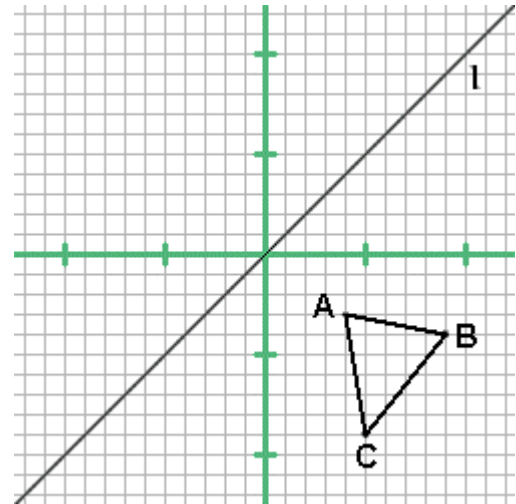

b) **Draw** the reflection of figure ABC using the y-axis as the line of reflection. Label corresponding points A_1 , B_1 , C_1 and **give** their **coordinates**.

A_1 _____

B_1 _____

C_1 _____

c) Now **draw** the reflection of figure ABC using the line l as the line of reflection. Label the corresponding points of your figure A_2 , B_2 , C_2 and **give** their **coordinates**.

A_2 _____

B_2 _____

C_2 _____

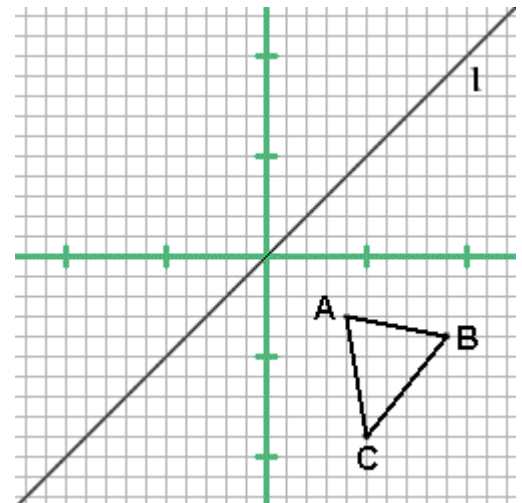

- d) **Draw** the figure produced when triangle ABC is rotated 270 degrees clockwise about the origin. Label the corresponding points of this figure A_3 , B_3 , C_3 and **give** their **coordinates**.

A_3 _____

B_3 _____

C_3 _____

